

For a better
climate™



Lindab

For a better climate

Annual Shareholders' Meeting
11 May 2023

Ola Ringdahl
President & CEO, Lindab Group



Lindab – For a better climate

“*To be the leading ventilation company in Europe, specialised in air distribution and air diffusion.*”

12 BSEK
in revenue

5,000
employees

20
countries

Numbers refer to 2022.



Market drivers

- Demand for clean air
- Energy efficiency
- Regulations

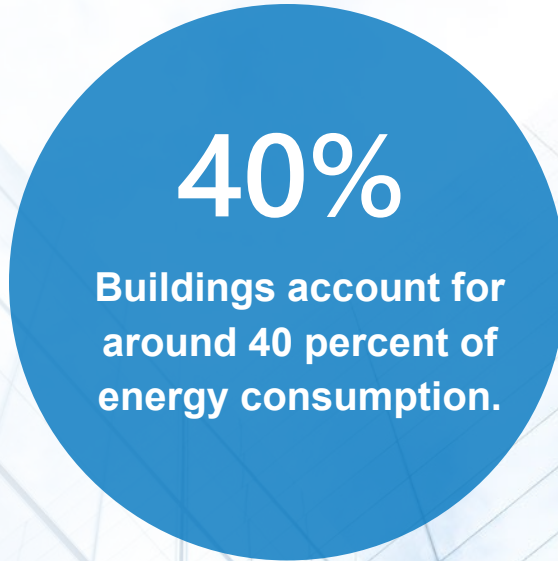

Renovation of buildings with high energy consumption

New construction of certified buildings

Products for renovation and new construction

Renovation



70%

Energy savings
through
renovation

Ultra BT

With Ultra BT you get demand-controlled ventilation as a retro-fit to your current system. No wires required.

New construction



80%

Energy savings
through new
construction

DCV ONE

The DCV system is an intelligent ventilation system based on variable air flow and indoor climate parameters.

Building a stronger and more focused Lindab

	2017	2022
Business areas	3	2
Countries	32	20
Employees	5,100	5,000
Sales	8,242	12,366
EBIT (adj), MSEK	492	1,347
EBIT (adj), %	6.0	10.9



Acquisitions of high-quality companies

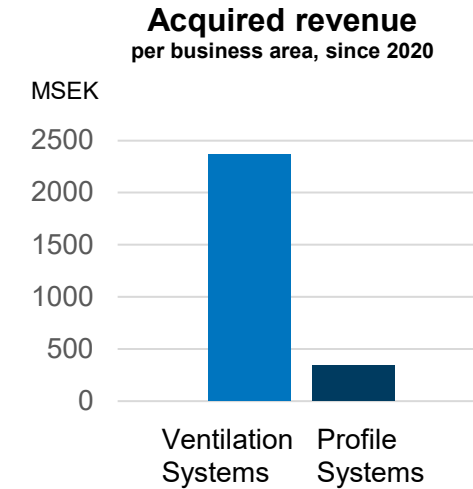
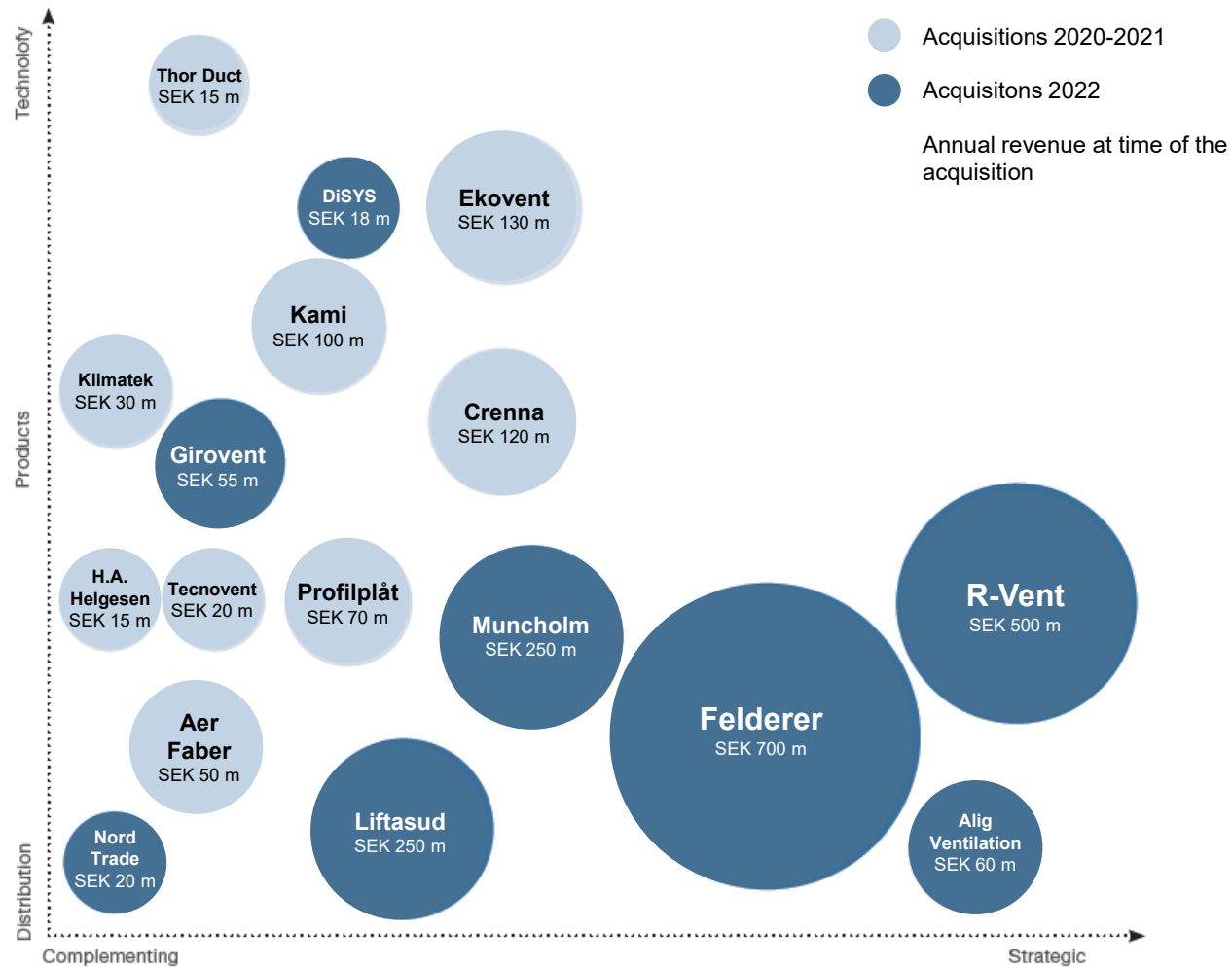

- 21 acquisitions since 2020.
- Contributed with 13% growth in 2022.

Acquisitions of high-quality companies

- Four acquisitions in 2023, two in Q1 and two in Q2.



February
Raab Lüftungstechnik, Germany
Revenue: SEK 160 m



March
Irish Ventilation & Filtration, Ireland
Revenue: SEK 100 m



April
Ventilace EU, Czech Republic
Revenue: SEK 42 m



May
Firmac, United Kingdom
Revenue: SEK 40 m

Investments to increase efficiency, capacity and safety

- SEK 359 m (395) invested in 2022, with attractive payback.
- The current investment program will continue until 2025.
- Focus on increased automation, expansion of capacity and improved safety.
- Investment in renewable energy for Lindab's production units.

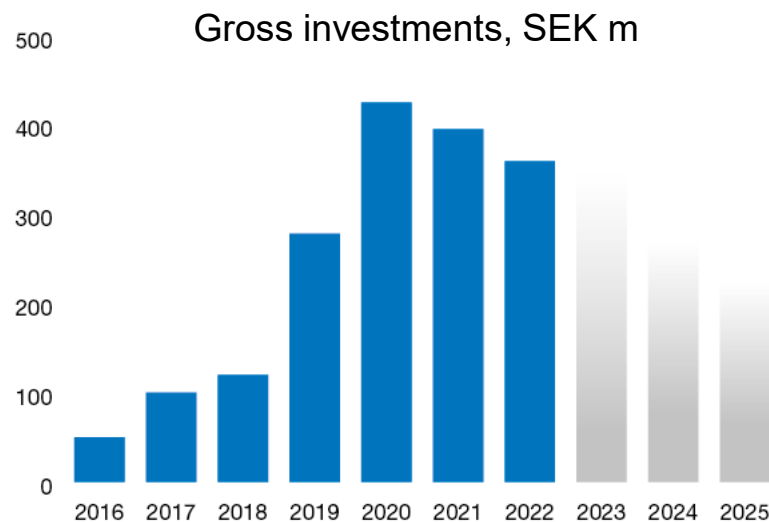

Automation of the T-piece production in Grevie (SE).



Laser cutting technology – one example of modernisation of Lindab's production platform



Logistic buildings in Grevie



Slitting line and tool robot

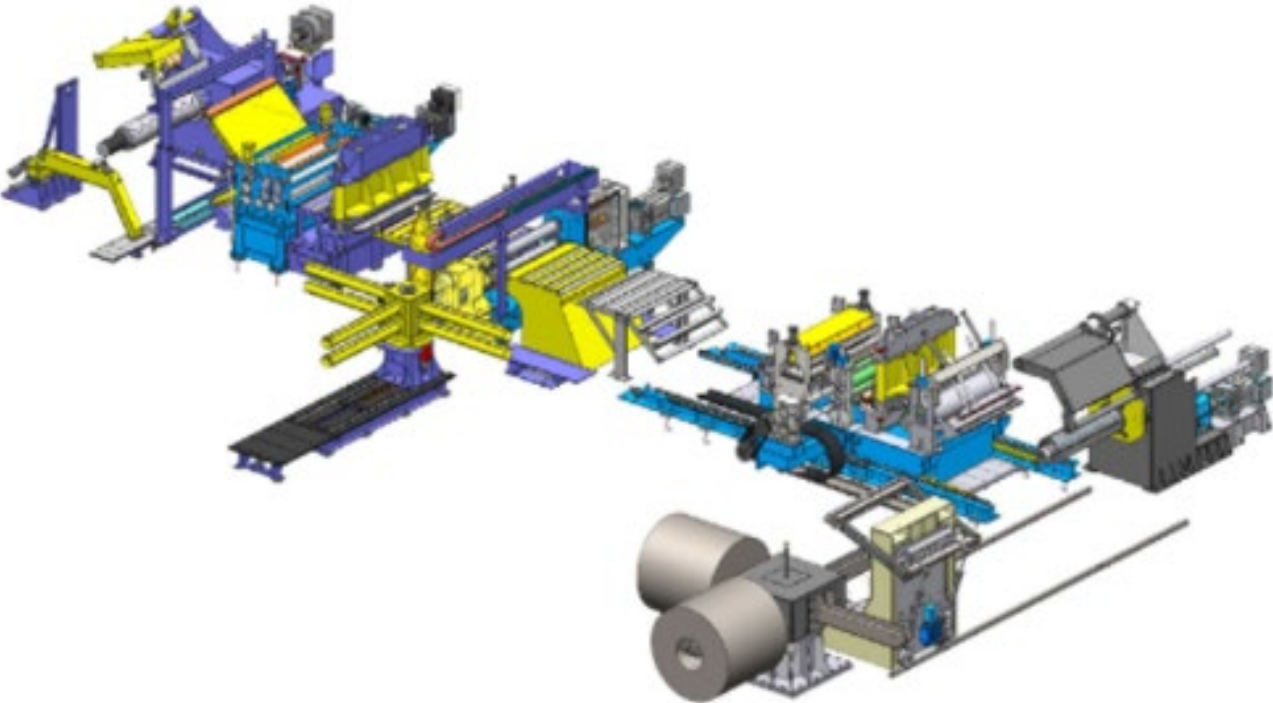

Re-branding of pro-shops

Refresh the layout and design of our pro-shops.



Lindab's sustainability plan



SCIENCE
BASED
TARGETS

For a better climate

FOR EVERYONE



FOR CUSTOMERS



FOR LINDAB



Attractive employer

Lindab Leadership Summit: Internal conference to develop our leaders.

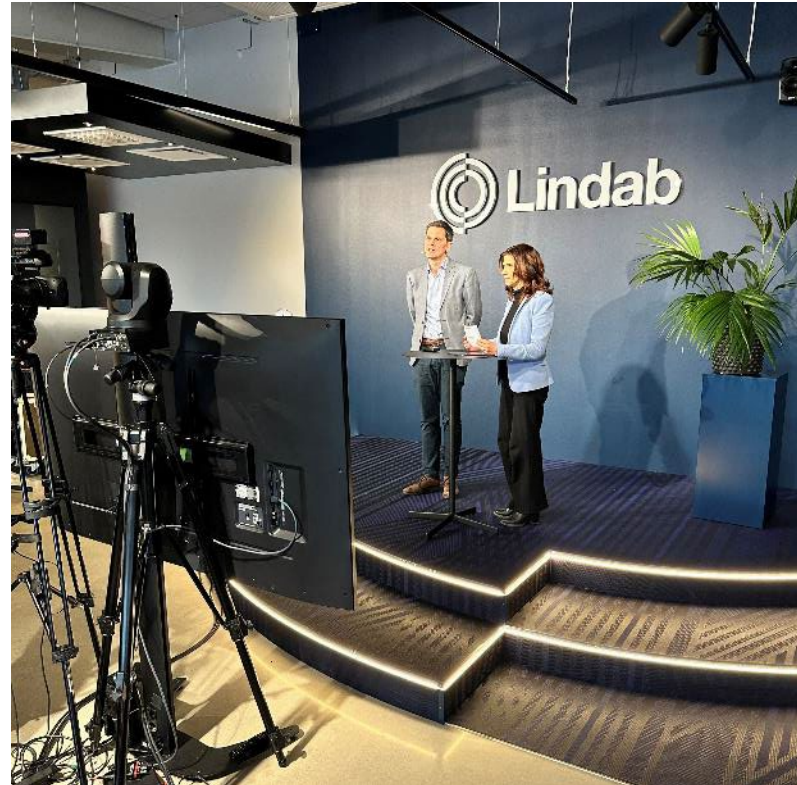



Lindab[®]

For a better climate